

Smart Dongle

- 4G Kit-G20
- 4G Kit-CN-G20
- 4G Kit-CN-G21

User Manual

Table of Contents

1 General Disclaimer	2
2 EU Declaration of Conformity	3
3 Product Introduction	4
3.1 Application Scenario	4
3.2 Product Model	4
3.3 Parts Introduction	5
3.4 Dimension	6
4 Installation	8
4.1 Deliverables	8
4.2 Install SIM Card and Smart Dongle	8
5 POWER ON	11
6 Commissioning via SolarGo App	12
7 Replace the Device	13
8 Troubleshooting	14
9 Technical Parameters	17

1 General Statement

- Due to product version upgrades or other reasons, the content of the document will be updated periodically. Unless otherwise agreed, the content of the document cannot replace the Safety Precautions in the product label. All descriptions in the document are for guidance only.
- Before operating the Installation equipment, please carefully read this document to understand the product and NOTICE precautions.
- All operations of the equipment must be performed by professional and qualified electrical technicians who are well-versed in the relevant standards and safety regulations of the project location.
- Before installing the Installation equipment, please check whether the deliverables type matches the order, whether the quantity is complete, and whether there is any damage to the appearance. If there are any abnormalities, please contact the after-sales service center.
- Damage to equipment or personal injury caused by failure to Installation, use, or configure the equipment in accordance with this document or the applicable user manual shall not be covered under beyond the manufacturer's liability. For more product warranty information, please visit the official website:<https://en.goodwe.com/warranty>

2 EU Declaration of Conformity

The Equipment with Wireless Communication Modules that can be sold in the European market meets the following directive requirements:

- Radio Equipment Directive 2014/53/EU (RED)
- Restrictions of Hazardous Substances Directive 2011/65/EU and (EU) 2015/863 (RoHS)
- Waste Electrical and Electronic Equipment 2012/19/EU
- Registration, Evaluation, Authorization and Restriction of Chemicals (EC) No 1907/2006 (REACH)

3 Product Introduction

3.1 Application scenario

The 4G Kit (referred to as the communication stick) can be used in conjunction with GoodWe Inverter to configure device parameters locally via Bluetooth, reference device operation information, or upload system operation data to the monitoring platform via 4G.

NOTICE
<ul style="list-style-type: none"> • This device is an LTE single-mode device, suitable for application scenarios with lower requirements for data transmission rates. • After inserting the Installation communication stick, you can configure the Inverter via Bluetooth proximity. • The 4G Kit-G20 currently does not support connection to third-party monitoring platforms. • The 4G Kit-CN-G20 and 4G Kit-CN-G21 support connection to third-party monitoring platforms via the MQTT communication protocol.

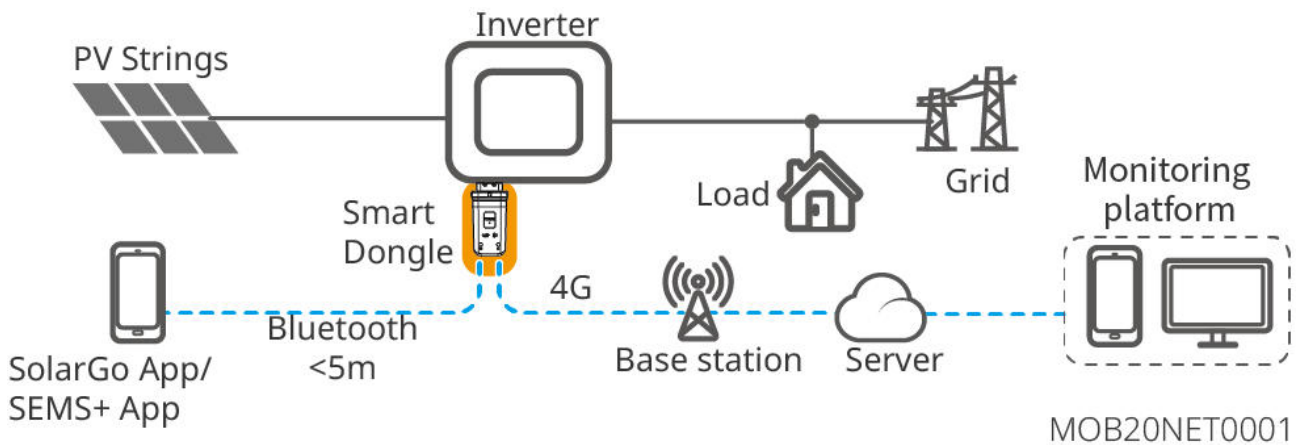

3.2 Product model

model	Signal type	Instructions
4G Kit-G20	4G, Bluetooth	
4G Kit-CN-G20 (Applicable to China only)	4G, Bluetooth	

model	Signal type	Instructions
4G Kit-CN-G21 (Applicable to China only)	4G, Bluetooth, GNSS	<ul style="list-style-type: none"> • Bluetooth: Configure device-related parameters via Bluetooth signal for proximity settings, and view operational information, error messages, etc. • 4G: Upload system operation information to the monitoring platform via 4G signal. • GNSS: Positioning devices via GNSS (Global Navigation Satellite System).

3.3 Component Introduction

4G Kit-G20

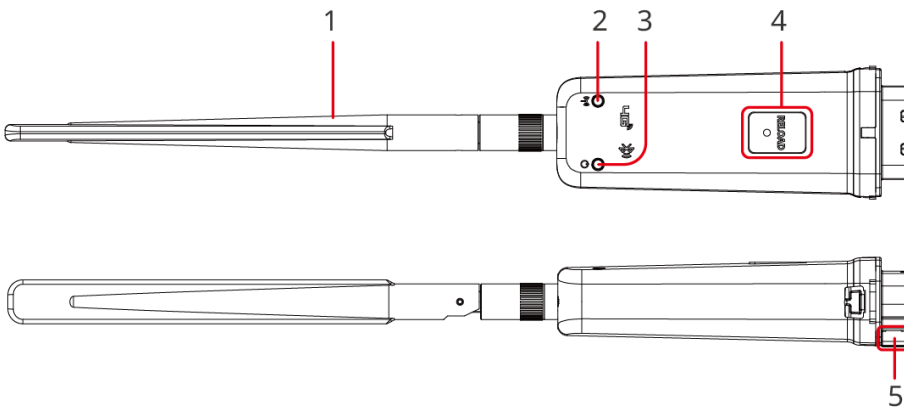

MOB20DSC0002

No.	component	No.	component
1	4G	2	Communication indicator
3	Power supply indicator	4	RELOAD button
5	Unlock button	-	-

4G Kit-CN-G20/4G Kit-CN-G21

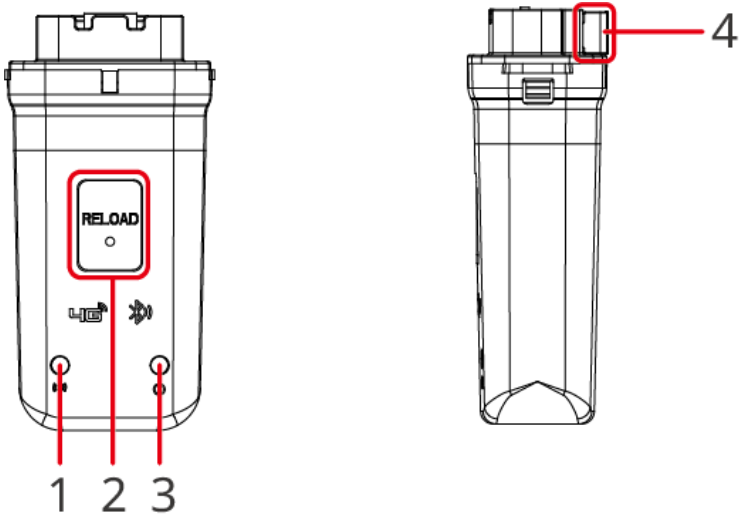

MOB20DSC0005

No.	component	No.	Component
1	Communication	2	Power supply indicator
3	RELOAD button	4	Unlock button

3.4 dimension

4G Kit-G20

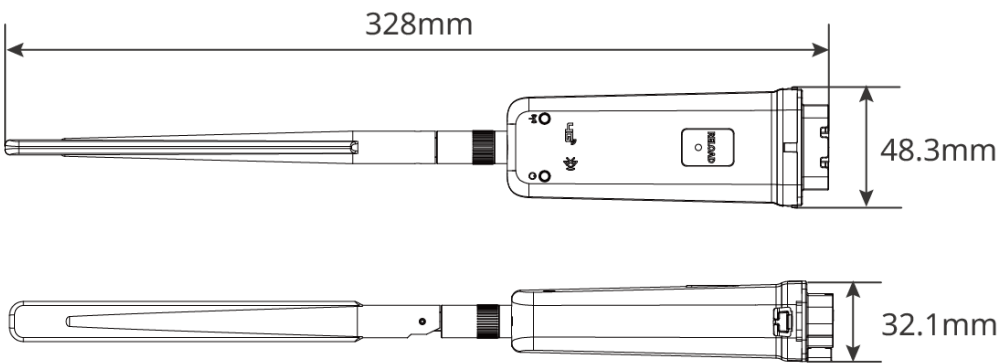

MOB20DSC0004



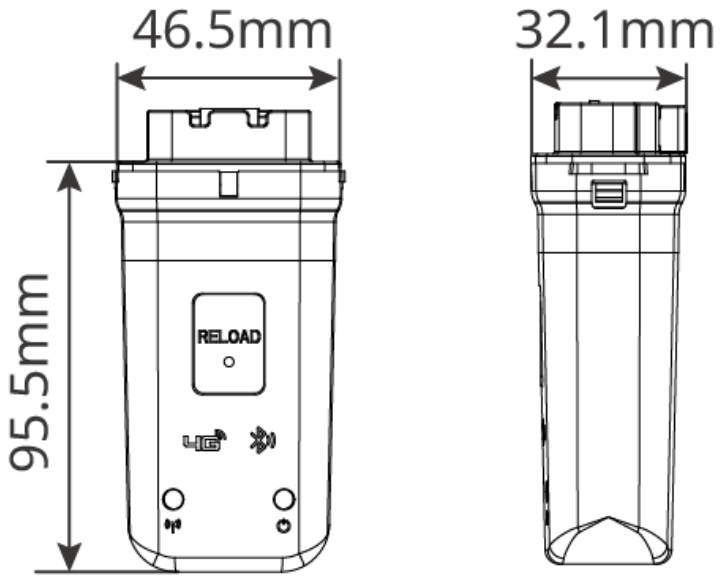

4G Kit-CN-G20 and/G Kit-CN-G21

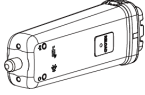
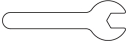
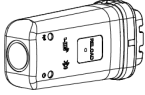

MOB20DSC0003

4 Installation

4.1 Attachment List

Component	Description	Component	Description
	4GSmart dongle x1		Wrench x1 Only applicable to scenarios where the SIM card is not selected. Only applicable to 4G Kit-G20.
			
	Product Information x1		antenna x1 Only applicable to 4G Kit-G20.
	Waterproof rubber ring x1 Only applicable to 4G Kit-G20.		Unlocking tool x1 Only applicable to scenarios without a configured SIM card. Only applicable to 4G Kit-G20.

4.2 Installation SIM card and communication stick

NOTICE

- Australia region standard-equipped Micro-SIM card, carrier is Orange, please confirm the device Installation is within the carrier's signal coverage area. For top-up, please contact the after-sales service center.
- China region standard-equipped Micro-SIM card, carrier is mobile communication. Please confirm that the device Installation is within the coverage area of the carrier's signal. If local mobile signal is not covered, please contact the after-sales service center to replace it with a communication card from another carrier.
- Except for Australia and China, please prepare your own Micro-SIM card with dimensions: 15*12mm and data usage $\geq 100\text{MB}/\text{month}$. To ensure normal operation in high and low temperature environments, industrial-grade SIM cards are recommended.
- When inserting a Micro-SIM card, please refer to the slot markings and arrow direction to avoid incorrect insertion.
- To remove the Micro-SIM card, push the SIM card inward and it will automatically pop out.
- To ensure the quality of 4G signal communication, do not Installation the device indoors or in areas with metal interference signals.
- To ensure accurate positioning, do not place the 4G Kit-CN-G21 Installation indoors, in obstructed locations, or in areas with signal interference.
- After inserting a Micro-SIM card, the communication stick can transmit information to the monitoring platform via 4G. If no SIM card is inserted, data transmission between the communication stick and the monitoring platform will not be possible.
- After the communication stick Installation is completed, please contact the after-sales service center to bind the Inverter with the communication stick. After binding, if you need to Installation the communication stick to another Inverter, please first contact the after-sales service center to unbind it.

Steps 1 to 4 are applicable only to scenarios where a Micro-SIM card needs to be self-provided.

Step 1 Dismantle communication rod tail Protection sleeve, and rotate counterclockwise to loosen the washer, hex nut, etc.

Step 2 Disassemble the communication stick using an external unlocking tool.

Step 3 Insert the prepared Micro-SIM card and assemble the communication stick. The click sound indicates that the module is properly assembled.

Step 4 Tighten the hex nut, washer, and external antenna by rotating clockwise.

Step 5 Insert the communication stick into the USB port of the Inverter.

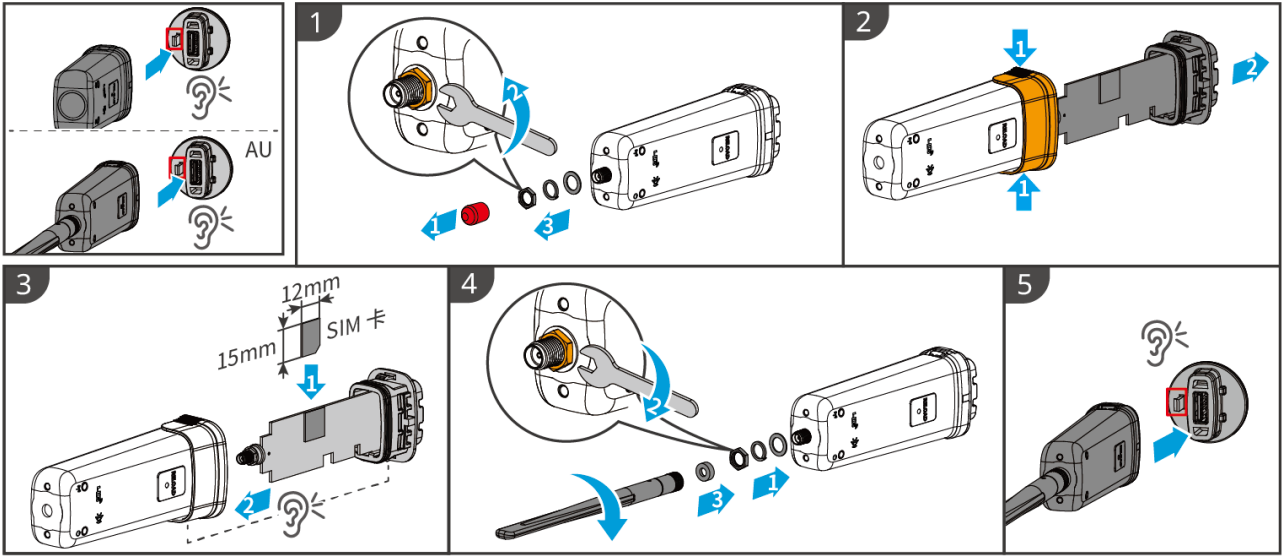









MOB20INT0005

5 power on

Step 1 Inverterpower on, Smart dongle completes the power on.

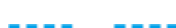
Step 2 Please determine the operation status of the communication rod in combination with the communication light on the Inverter side.

indicator	indicator status	Description
		Constant light = Smart dongle has been power on.
		Extinguish = Smart dongle not power on.
		Constant light = Smart dongle is connected to Server, communication is normal.
		Single flash = Smart dongle is in Bluetooth broadcast mode. 【1】
		Double flash = Smart dongle not connected to the communication base station.
		Four flashes = Smart dongle is connected to the communication base station but not connected to Server.
		Six flashes = Communication between Smart dongle and Inverter is disconnected.
		Off = Smart dongleSoftware reset in progress or not power on.
Button	Instructions	
RELOAD	Double-click Smart dongle to enable Bluetooth broadcasting. 【1】	
	Press and hold for 0.5~3s, Smart dongle will restart.	
	Press and hold for 6~20 seconds, Smart dongle will restore factory settings.	

【1】 Only applicable to 4G Kit-G20.

6 Through the SolarGo App Commissioning device

NOTICE

- Connect to the SolarGo App via Bluetooth to configure device-related parameters or view operational parameters, alarms, and other information.
- During the parameter setting process, SIM card-related parameters can be obtained from the SIM card operator.

Step 1 Download and Installation the SolarGo App. The interface may vary depending on the app version; please refer to the actual display. Scan the QR code below to access the latest SolarGo App User Manual.

Step 2 Follow the prompts on the App interface to connect the device (LGA-***/GSA-***/GSB-***) via Bluetooth signal.

GSA-*****

1

2

1	<p>smart dongle type</p> <ul style="list-style-type: none"> • GSA: 4G Kit-CN-G20 • GSB: 4G Kit-CN-G21 • LGA: 4G Kit-G20
2	Inverterserial number

Step 3 When connecting to the device via Bluetooth for the first time, a Bluetooth pairing prompt will appear on the interface. Please click "Pair" to continue the connection and proceed to the login screen.

Step 4 Log in to the App according to your actual role, with the initial login password: 1234.



SolarGo App



SolarGo App User Manual

7 Replace equipment

Step 1 (Optional) If already bound to Inverter, please contact the after-sales service center to unbind it first.

Step 2 Prepare the new communication stick before replacement.

Step 3 Remove the communication bar from the Inverter.

Step 4 Installation new communication rod.

NOTICE

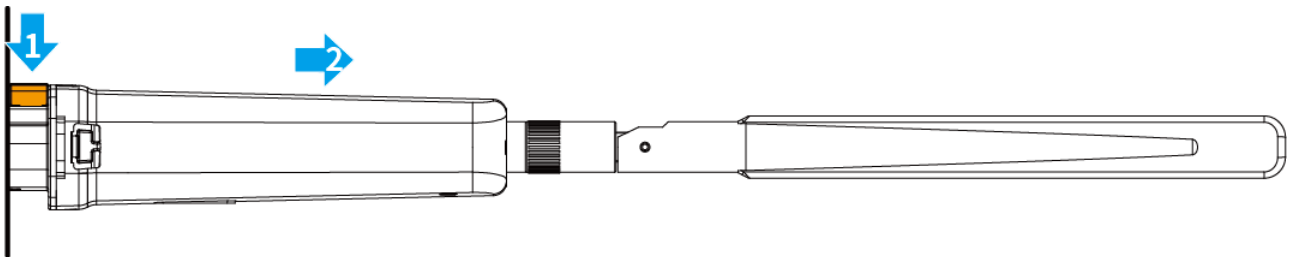

- Some Inverter do not support hot swapping. Please power off the device before replacing the communication module.
- Do not power off when Smart dongle or Inverter is performing a firmware upgrade, as this may cause the upgrade to fail.





MOB20INT0006

8 Troubleshooting

Please follow the below methods to troubleshoot fault. If the troubleshooting methods do not resolve the issue, please contact the after-sales service center.

No.	fault	fault cause	Solution measures
1	Unable to locate LGA-***/GSA-***/GSB-***	Handheld terminal device Bluetooth did not detect Smart dongle	<ol style="list-style-type: none"> 1. Ensure the communication bar is powered properly.  indicator is in a single flash or steady-on state. 2. Ensure the handheld terminal device is within the communication range of the communication rod. 3. Double-click the RELOAD button,  indicator single flash followed by device search again. 4. Refresh the App device list. 5. Restart the Inverter.
2	Unable to connect to LGA-***/GSA-***/GSB-***	The Bluetooth of the handheld terminal device is not paired with the Bluetooth of the communication stick.	<ol style="list-style-type: none"> 1. Ensure Bluetooth is successfully paired. 2. Restart Inverter and reconnect to LGA-***/GSA-***/GSB-***. 3. In the Bluetooth settings of the handheld terminal device, unpair from LGA-***/GSA-***/GSB-***, then reconnect via the App.

No.	fault	fault cause	Solution measures
3	 indicator continuous double flash	Smart dongle failed to connect to the communication base station	<ol style="list-style-type: none"> 1. 4G Kit-G20 Please ensure that the external antenna Installation is properly installed and keep the area around the antenna clear and unobstructed. 2. Ensure the communication rod Installation location is within the well-covered signal area of the communication base station. 3. Check the SIM card status to ensure it is not in arrears or deactivated. 4. Ensure the SIM card Installation is properly installed and not detached. 5. Replug the communication stick. 6. Restart Inverter.
4	 indicator continuous four flashes	Smart dongle is not connected to Server	<ol style="list-style-type: none"> 1. 4G Kit-G20 Please ensure the external antenna Installation is properly installed and keep the area around the antenna clear and unobstructed. 2. Ensure the communication rod Installation location is within the well-covered signal area of the communication base station. 3. Check the SIM card status to ensure it is not in arrears or deactivated. 4. Replug the communication stick. 5. Restart Inverter.

No.	fault	fault cause	Solution measures
5	 indicator continuous six flashes	Smart dongle communication with Inverter is disconnected	<ol style="list-style-type: none"> 1. Check if Smart dongle and Inverter are properly connected. 2. Check the Inverter model to confirm compatibility with the communication stick. 3. Reinsert the communication stick. 4. Restart Inverter.

9 technical parameter

Product model	4G Kit-CN-G20	4G Kit-CN-G21	4G Kit-G20
Equipment Management			
Maximum supported Inverter quantity	1	1	1
Power supply parameters			
voltage (V)	5	5	5
Power Consumption (W)	≤4	≤4	≤5
Interface method	USB	USB	USB
Communication parameters			
4G/3G/2G	LTE-FDD: B1/B3/B5/B8 LTE-TDD: B34/B39/B40/B41	LTE-FDD: B1/B3/B5/B8 LTE-TDD: B34/B39/B40/B41	LTE-FDD: B1/2/3/4/5/7/8/12/13/18/19/20/25/26/28/66 LTE-TDD: B34/38/39/40/41 WCDMA: B1/2/4/5/6/8/19 GSM/EDGE: B2/3/5/8
GNSS positioning	/	BeiDou, GPS	/
Bluetooth	Bluetooth V5.0	Bluetooth V5.0	Bluetooth V5.0
Mechanical parameters			
Dimensions (W × H × D mm)	48.3*95.5*32.1	48.3*95.5*32.1	48.3*138*32.3

Product model	4G Kit-CN-G20	4G Kit-CN-G21	4G Kit-G20
Weight (g)	87	87	99
indicator	LED* 2	LED* 2	LED* 2
Mounting method	Plug and Play	Plug and Play	Plug and Play
SIM card size	Micro sim,15mm*12mm	Micro sim,15mm*12mm	Micro sim,15mm*12mm
Environmental parameters			
Operating Temperature Range (°C)	-30~+65	-30~+65	-30~+65
Storage temperature range (°C)	-40~+70	-40~+70	-40~+70
Relative Humidity	0-100%	0-100%	0-100%
IP rating	IP66	IP66	IP66
Max. Operating Altitude (m)	4000	4000	4000



Official Website

GoodWe Technologies Co., Ltd.

 No. 90 Zijin Rd., New District, Suzhou, 215011, China

 www.goodwe.com

 service@goodwe.com



Local Contacts